

Wire Rope Replacement Criteria

TECH TIP 2

For more details, see ASME code/standard excerpts below (the applicable code/standard differs by jurisdiction and therefore we have listed both ASME A17.1b-2009/B44b-09 and ASME A17.6-2010 information in this Tech Tip - local code always takes precedence).

The replacement criteria for steel wire ropes fall into four categories:

1) Crown breaks: The crown wires are those that make contact with the sheave and they will show signs of abrasion. If enough abrasion and/or rope fatigue due to bending takes place, the crown wires will break. When using this criterion, an inspector is looking for the number of total crown wire breaks within a rope lay. A rope lay is approximately 6.5 times the diameter of the rope. For example, the rope lay

for 3/8 in • 9.5 mm ropes is 2.44 in • 62 mm, for 1/2 in • 12.7 mm ropes is 3.25 in • 83 mm and for 5/8 in • 15.9 mm ropes is 4.06 in • 103 mm.

2) Valley breaks: The valley wires are located in the valleys of two adjacent strands. They do not make contact with the sheave and therefore should not experience abrasion. Valley breaks are attributed to rope fatigue due to bending.

3) Diameter reduction: If the ropes reach a specified diameter reduction, they should be replaced even if no crown or valley breaks are present.

4) Red dust or rouge: The existence of red dust, or rouge, is also a factor in determining rope replacement.

EXCERPTS FROM ASME A17.1b-2009/CSA B44b-09, PART 8

8.11.2.1.3(cc) Wire Suspension and Compensating Ropes

8.11.2.1.3(cc)(1) Wire suspension and compensating ropes shall be replaced:

(a) if the broken wires are equally distributed among the strands, when the number of broken wires per rope lay in the worst section of the rope exceeds the values shown in column A of Table 8.11.2.1.3(cc)(1); or

(b) if the distribution of the broken wires is unequal, and broken wires predominate in one or two strands, when the number of broken wires per rope lay in the worst section of the rope exceeds the values shown in column B of Table 8.11.2.1.3(cc)(1); or

(c) if four or five wires, side by side, are broken across the crown of any strand, when the number of broken wires per rope lay in the worst section of rope exceeds values shown in column C of Table 8.11.2.1.3(cc)(1); or

(d) if in the judgment of the inspector, any unfavorable condition, such as fretting corrosion (red dust or rouge), excessive wear of individual wires in the strands, unequal tension, poor sheave grooves, etc., exists, the criteria for broken wires will be reduced by 50% of the values indicated in Table 8.11.2.1.3(cc)(1) for any of the three conditions described above; or

(e) if there is more than one valley break per rope lay.

Table 8.11.2.1.3(cc)(1) Wire Suspension and Compensation Ropes

Types of Wire Rope	A*	B*	C*
6x19 class (6 strands w/ 16-26 wires/strand)	24-30	8-12	12-20
8x19 class (8 strands w/ 16-26 wires/strand)	32-40	10-16	16-24

*The upper limits may be used when inspections are made monthly by a competent person.

8.11.2.1.3(cc)(2) On winding drum machines, the ropes shall be replaced:

(a) if the broken wires are equally distributed among the strands, when the number of broken wires per rope lay in the worst section of rope exceeds 12 to 18; or

(b) if wire breaks predominate in one or two strands, when the number of broken wires per rope lay in the worst section of rope exceeds 6 to 12; or

(c) if there is more than one valley break per rope lay.

8.11.2.1.3(cc)(3) On any type of elevator, the suspension, compensation and governor ropes shall be replaced when their actual diameter is reduced below the value shown in Table 8.11.2.1.3(cc)(3):

Reprinted from ASME A17.1b-2009/CSA B44b-09, Part 8 and A17.6-2010, Section 1.10 with permission of The American Society of Mechanical Engineers. All rights reserved.

Table 8.11.2.1.3(cc)(3)

Nominal Size inches	Maximum Reduced Diameter inches • decimal inches
3/8	11/32 • 0.344
7/16	13/32 • 0.406
1/2	15/32 • 0.469
9/16	17/32 • 0.531
5/8	37/64 • 0.578
11/16	41/64 • 0.641
3/4	45/64 • 0.703
1	15/16 • 0.938

8.6.3.2 Replacement of a Single Suspension Rope

If one rope of a set is worn or damaged and requires replacement, the entire set of ropes shall be replaced, except, where one rope has been damaged during installation or acceptance testing prior to being subjected to elevator service, it shall be permissible to replace a single damaged rope with a new rope, provided that the requirements of 8.6.3.2.1 through 8.6.3.2.6 are met.

8.6.3.2.1 The wire rope data for the replacement rope must correspond to the wire rope data specified in 2.20.2.2(a), (b), (c), (f), and (g) for the other ropes.

8.6.3.2.2 The replacement rope shall be provided with a wire rope data tag conforming to 2.20.2.2.

8.6.3.2.3 The suspension ropes, including the damaged rope, shall not have been shortened since their original installation.

8.6.3.2.4 The diameter of any of the remaining ropes shall not be less than the nominal diameter minus 0.4 mm (0.015 in.).

8.6.3.2.5 The tension of the new replacement rope shall be checked and adjusted as necessary at semi-monthly intervals over a period of not less than two months after installation. If proper equalization of rope tension cannot be maintained after six months, the entire set of hoist ropes shall be replaced.

8.6.3.2.6 The replacement rope shall be provided with the same type of suspension-rope fastening used with the other ropes.

When using a caliper to measure wire rope, measure from crown to crown...

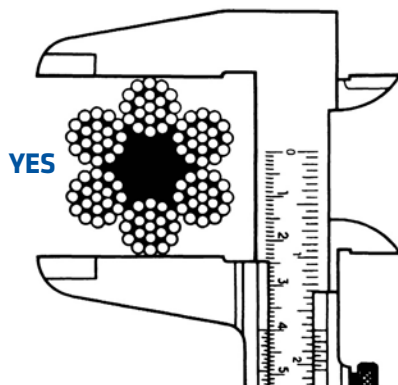

8.6.3.3 Replacement of Ropes Other than Governor Ropes

8.6.3.3.1 Replacement of all ropes, except governor ropes (see 8.6.3.4) shall conform to the following:

- (a) Replacement ropes shall be as specified by the original elevator manufacturer or be at least equivalent in strength, weight, and design.
 - (b) Ropes that have been previously used in another installation shall not be reused.
 - (c) When replacing suspension, compensating, and car or drum counterweight ropes, all ropes in a set shall be replaced, except as permitted by 8.6.3.2.
 - (d) The ropes in the set shall be new, all from the same manufacturer, and of the same material, grade, construction, and diameter.
- NOTE: ASME A17.1/CSA B44 does not require that the ropes be from the same master reel.**
- (e) Data tags conforming to 2.20.2.2 shall be applied.
 - (f) Suspension, car, and drum counterweight rope fastenings shall conform to 2.20.9.

8.6.3.4 Replacement of Governor or Safety Rope

8.6.3.4.1 Governor ropes shall be of the same size, material, and construction as the rope specified by the governor manufacturer, except that a rope of the same size but of different material or construction shall be permitted to be installed in conformance with 8.7.2.19.

8.6.3.4.2 The replaced governor ropes shall comply with 2.18.5.

8.6.3.4.3 After a governor rope is replaced, the governor pull-through force shall be checked as specified in 8.11.2.3.2(b).

8.6.3.4.4 A test tag indicating the date when the pull-through test was performed shall be attached.

NOTE: Some in the industry believe that all ropes for an installation must be cut from the same master reel. This is not stated in ASME A17.1/CSA B44.

...and not from valley to valley.

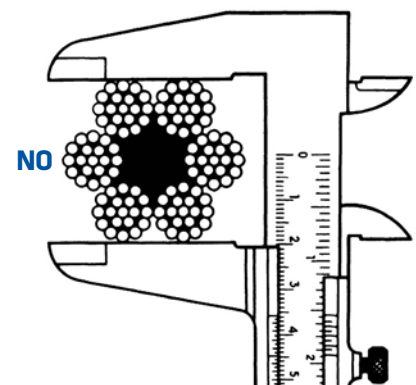

EXCERPTS FROM ASME A17.6-2010, SECTION 1.10

Notes:

(1) Replacement criteria for steel wire rope are based on the worst conditions of diameter and wire breaks. Crown wires are subject to both wear that reduces the diameter of the rope and the breaks that occur in the wear area. Breaks that are visible and occur outside of the crown wear area with the crown wire intact are called valley breaks.

(2) Where ropes are subjected to reverse bends or where ropes are installed on nonmetallic sheaves or sheaves with nonmetallic liners or inserts, extra attention must be given to the rope due to possible acceleration of valley breaks.

1.10.1 Traction Drive Machines

1.10.1.1 Replacement requirements for steel wire suspension ropes for traction elevators shall be as follows (see Nonmandatory Appendix A):

(a) The steel wire rope(s) shall be replaced if the rope is permanently kinked, bent, or deformed in any way (see 1.10.5).

(b) For rope diameters equal to or greater than 8 mm (0.315 in.), the ropes shall be replaced in accordance with 1.10.1.2(a) through 1.10.1.2(g) and 1.10.3.

(c) For rope diameters less than 8 mm (0.315 in.), the ropes shall be replaced in accordance with 1.10.1.2(a) through (g), 1.10.1.2.1 and 1.10.1.2.2, and 1.10.3. In addition, other replacement criteria based on the application shall be permitted to be applied. The replacement criteria shall be documented in the Maintenance Control Program (see ASME A17.1/CSA B44, requirement 8.6.1.4.1).

1.10.1.2 Criteria for replacement include at least one of the following:

(a) if the broken crown wires are equally distributed among the strands, when the number of broken wires per rope lay in the worst section of rope exceeds the values shown in the "Normal Wear Conditions," first column of Table 1.10.1.2-1

(b) if the distribution of breaks is unequal and broken crown wires predominate in one or two strands, when the number of broken wires per rope lay in the worst section of rope or the minimum diameter exceeds the values shown in the "Normal Wear Conditions," first column of Table 1.10.1.2-1

(c) if four wires, side by side, are broken across the crown of any strand, when the number of broken wires per rope lay in the worst section of rope exceeds the values shown in the "Normal Wear Conditions," first column of Table 1.10.1.2-1

(d) if an unfavorable condition exists, such as but not limited to corrosion due to external conditions, excessive wear of individual

wires in the strands, unequal tension, poor sheave grooves; the criteria for broken crown wires shall be the values indicated in the "Unfavorable Wear Conditions," second column of Table 1.10.1.2-1 for any of the conditions described above

(e) if red dust or rouge exists, the criteria for broken wires shall be the values indicated in the "Rope Showing Rouge," third column of Table 1.10.1.2-1 for any of the conditions described above

(f) if there is more than one valley break per rope lay

(g) if there are any valley breaks at any location where rouge exists
1.10.1.2.1 The elevator manufacturer using information from the rope manufacturer and considering the application, shall establish the design life limit to ensure that the residual strength of wire ropes less than 8 mm (0.315 in.) diameter is not less than 60% of the minimum breaking force at the time of replacement.

1.10.1.2.2 Steel wire ropes of less than 8 mm (0.315 in.) in diameter shall be replaced when there is evidence of rouge.

Table 1.10.1.2-1 Wire Breaks: Crown Wire Breaks Per Lay Length

6-Strand Rope Applications	Normal Wear Conditions	Unfavorable Wear Conditions	Ropes Showing Rouge
Distributed breaks (max.)	24	12	12
Unequal breaks (max.)	8	4	4
4 Side-by-Side breaks	12	6	6
8- and 9-Strand Rope Applications	Normal Wear Conditions	Unfavorable Wear Conditions	Ropes Showing Rouge
Distributed breaks (max.)	32	16	16
Unequal breaks (max.)	10	5	5
4 Side-by-Side breaks	16	8	8

GENERAL NOTES:

(a) Where ropes are subjected to reverse bends or where ropes are installed on nonmetallic coated, plastic, fiber-reinforced plastic sheaves or sheaves with nonmetallic liners or inserts, extra attention must be given to any steel wire rope (6, 8, or 9 strand) due to possible acceleration of valley breaks.

(b) This table does not apply to Winding Drum Machines. See 1.10.2 for replacement criteria.

(c) No more than one valley break per lay length and no valley breaks allowed if visible rouge.

(d) For ropes less than 8 mm, also see 1.10.1.2.2 for additional replacement requirements.

1.10.2 Winding Drum Machines

Suspension ropes shall be replaced on winding drum machines if:

- (a) the broken crown wires are equally distributed among the strands, when the number of broken wires per rope lay in the worst section of rope exceeds 12;
- (b) the broken crown wires predominate in one or two strands, when the number of broken wires per rope lay in the worst section of rope exceeds 6;
- (c) there is more than one valley break per rope lay; or
- (d) there are any valley breaks at any location where rouge exists.

1.10.3 All Elevator Types

The suspension, compensation, and governor ropes shall be replaced when their actual diameter is reduced below the value shown in Table 1.10.3-1 (see next page). For nominal diameters not listed in Table 1.10.3-1, the minimum diameter reduction shall be calculated using the criteria outlined in General Notes (a) and (b) of Table 1.10.3-1. Normal wear diameters, unfavorable wear, and rouge conditions as listed in the table shall apply. Compensation and governor ropes shall also conform to 1.10.1.1(a) and 1.10.1.2(a) through 1.10.1.2(g).

Measurement for diameter shall be taken on a straight portion of rope at the worst location. Two measurements at the same position at right angles shall be taken. The ropes shall be replaced if both of these measurements are below the replacement value. However, if only one of the measurements is below the replacement value, then the criteria for wire breaks under "Unfavorable Wear Conditions" shall apply. See Table 1.10.1.2-1.

1.10.4 Replacement of Ropes

Replacement of all ropes, except governor ropes (see ASME A17.1/CSA B44, requirement 8.6.3.4), shall conform to the requirements of 1.10.4.1 through 1.10.4.6.

1.10.4.1 Replacement ropes shall be as specified by the original elevator manufacturer or be at least equivalent in strength, weight, and design.

1.10.4.2 Ropes that have previously been installed and used on another installation shall not be reused.

1.10.4.3 When replacing suspension, compensating, and car or drum counterweight ropes, all ropes in a set shall be replaced, except as permitted by 1.10.5.

1.10.4.4 The ropes in the set shall be new, all from the same manufacturer and of the same material, grade, construction, and diameter.

1.10.4.5 Data tags conforming to ASME A17.1/CSA B44, requirement 2.20.2.2 shall be applied.

1.10.4.6 Suspension, car, and drum counterweight rope fastenings shall conform to ASME A17.1/CSA B44, requirement 2.20.9.

1.10.5 Replacement of a Single Suspension Rope

If one rope of a set is worn or damaged and requires replacement, the entire set of ropes shall be replaced; except, where one rope has been damaged during installation or acceptance testing prior to being subjected to elevator service, it shall be permissible to replace a single damaged rope with a new rope provided that the requirements of 1.10.4.4 and 1.10.5.1 through 1.10.5.1.6 are met. NOTE: Damage includes but is not limited to kinked ropes.

1.10.5.1 The steel wire rope data for the replacement rope must correspond to the steel wire rope data specified in ASME A17.1/CSA B44, requirement 2.20.2.2.

1.10.5.2 The replacement rope shall be provided with a data tag conforming to ASME A17.1/CSA B44, requirement 2.20.2.2.

1.10.5.3 The suspension ropes, including the damaged rope, shall not have been shortened since their original installation.

1.10.5.4 The diameter of any of the remaining ropes shall not be less than the nominal diameter minus 0.4 mm (0.015 in.).

1.10.5.5 The tension of the new replacement rope shall be checked and adjusted as necessary at semi-monthly intervals over a period of not less than 2 months after installation. If proper equalization of the rope tension cannot be maintained after 6 months, the entire set of suspension ropes shall be replaced.

1.10.5.6 The replacement rope shall be provided with the same type of suspension rope fastening used with the other ropes.

NOTE: Some in the industry believe that all ropes for an installation must be cut from the same master reel. This is not stated in ASME A17.6.

**Table 1.10.3-1 Imperial Minimum Diameter
6-, 8-, and 9-Strand Rope Applications**

Nominal Rope Size	Normal Wear Conditions	Unfavorable Wear Conditions	Ropes Showing Rouge
1/4 in.	0.242 in.	0.242 in.	Note (1)
5/16 in.	0.303 in.	0.303 in.	Note (1)
3/8 in.	0.352 in.	0.352 in.	0.363 in.
7/16 in.	0.410 in.	0.410 in.	0.424 in.
1/2 in.	0.469 in.	0.469 in.	0.484 in.
9/16 in.	0.527 in.	0.527 in.	0.545 in.
5/8 in.	0.586 in.	0.586 in.	0.605 in.
11/16 in.	0.645 in.	0.645 in.	0.666 in.
3/4 in.	0.703 in.	0.703 in.	0.727 in.
13/16 in.	0.762 in.	0.762 in.	0.787 in.
7/8 in.	0.820 in.	0.820 in.	0.848 in.
15/16 in.	0.879 in.	0.879 in.	0.908 in.
1 in.	0.938 in.	0.938 in.	0.969 in.
1 1/8 in.	1.055 in.	1.055 in.	1.090 in.
1 1/4 in.	1.172 in.	1.172 in.	1.211 in.
1 3/8 in.	1.289 in.	1.289 in.	1.332 in.
1 1/2 in.	1.406 in.	1.406 in.	1.453 in.

**Table 1.10.3-1 Metric Minimum Diameter
6-, 8-, and 9-Strand Rope Applications**

Nominal Rope Size	Normal Wear Conditions	Unfavorable Wear Conditions	Ropes Showing Rouge
4 mm	3.875 mm	3.875 mm	Note (1)
5 mm	4.844 mm	4.844 mm	Note (1)
6 mm	5.813 mm	5.813 mm	Note (1)
6.5 mm	6.297 mm	6.297 mm	Note (1)
6.7 mm	6.491 mm	6.491 mm	Note (1)
8 mm	7.500 mm	7.500 mm	7.750 mm
9 mm	8.438 mm	8.438 mm	8.719 mm
10 mm	9.375 mm	9.375 mm	9.688 mm
11 mm	10.31 mm	10.31 mm	10.66 mm
12 mm	11.25 mm	11.25 mm	11.63 mm
13 mm	12.19 mm	12.19 mm	12.59 mm
14 mm	13.13 mm	13.13 mm	13.56 mm
15 mm	14.06 mm	14.06 mm	14.53 mm
16 mm	15.00 mm	15.00 mm	15.50 mm
18 mm	16.88 mm	16.88 mm	17.44 mm
19 mm	17.81 mm	17.81 mm	18.41 mm
20 mm	18.75 mm	18.75 mm	19.38 mm
22 mm	20.63 mm	20.63 mm	21.31 mm

GENERAL NOTES:

- (a) Maximum allowable diameter reduction below nominal for rope diameters less than 8 mm is 3.125%.
- (b) Maximum allowable diameter reduction below nominal for rope diameters equal to or greater than 8 mm are as follows:
 - (1) Normal wear or unfavorable wear conditions is 6.25%.
 - (2) Ropes showing rouge is 3.125%.

NOTE: (1) For ropes less than 8 mm, the rope must be replaced if rouge is evident. See 1.10.1.2.2.